

GNAT 1 OF 10

BLOCK DIAGRAM

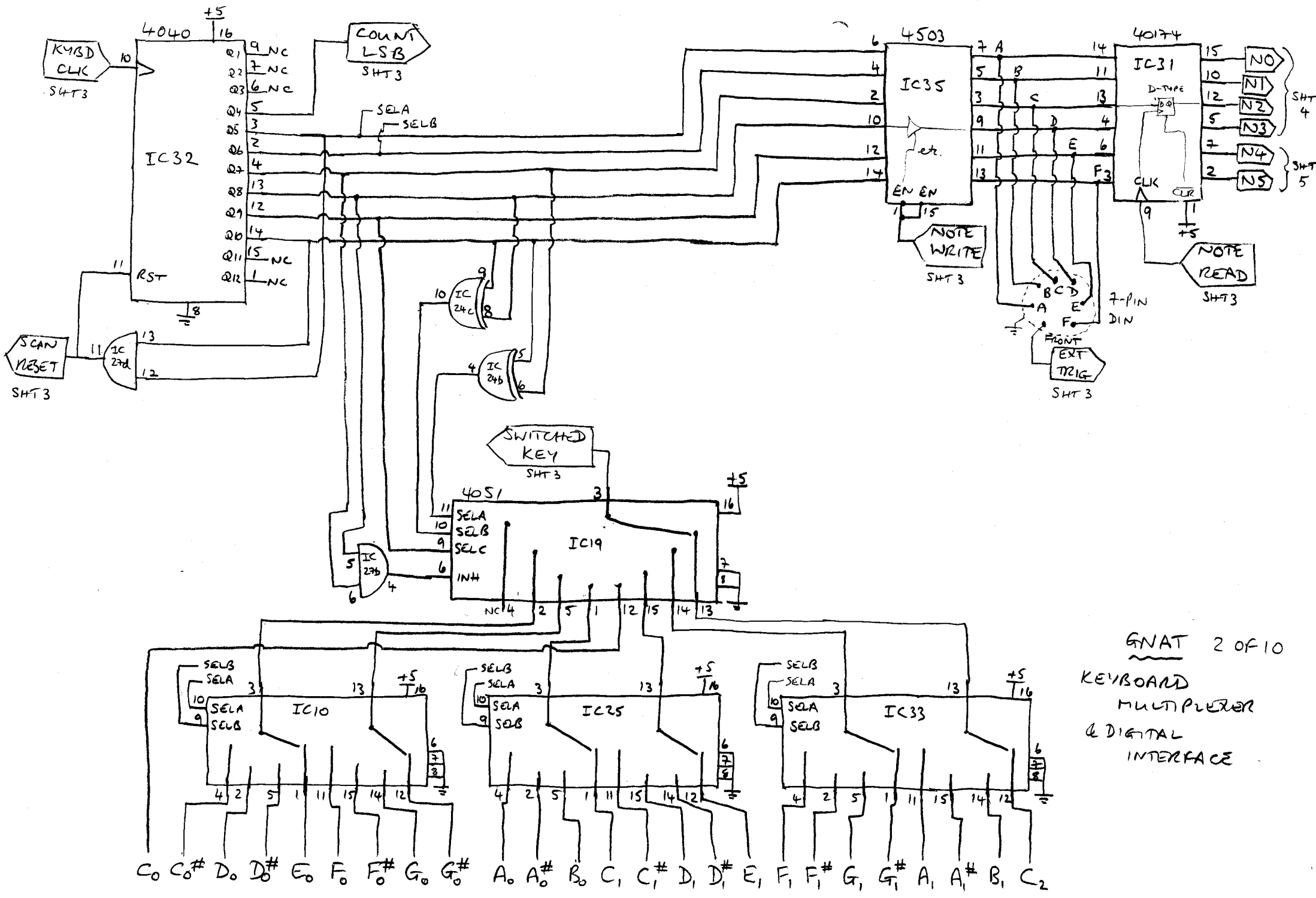

GNAT 2 OF 10
 KEYBOARD
 MULTIPLEXER
 & DIGITAL
 INTERFACE

C₀ C₀# D₀ D₀# E₀ F₀ F₀# G₀ G₀# A₀ A₀# B₀ C₁ C₁# D₁ D₁# E₁ F₁ F₁# G₁ G₁# A₁ A₁# B₁ C₂

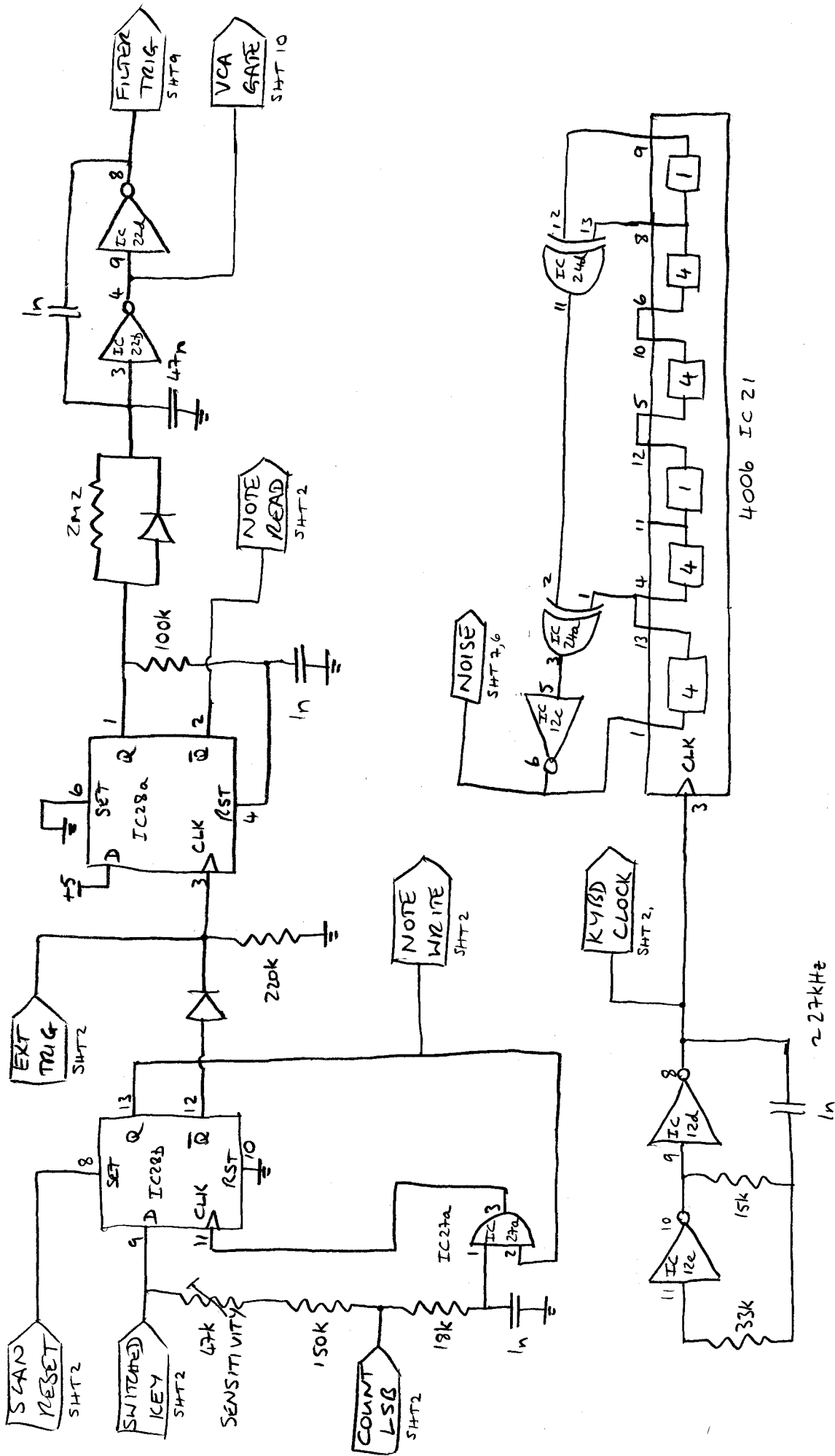

GNAI 3 OF 10
 KEYBOARD TRIGGERS CLOCK,
 NOISE

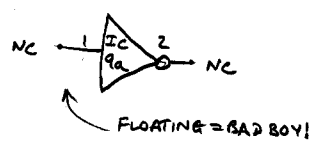
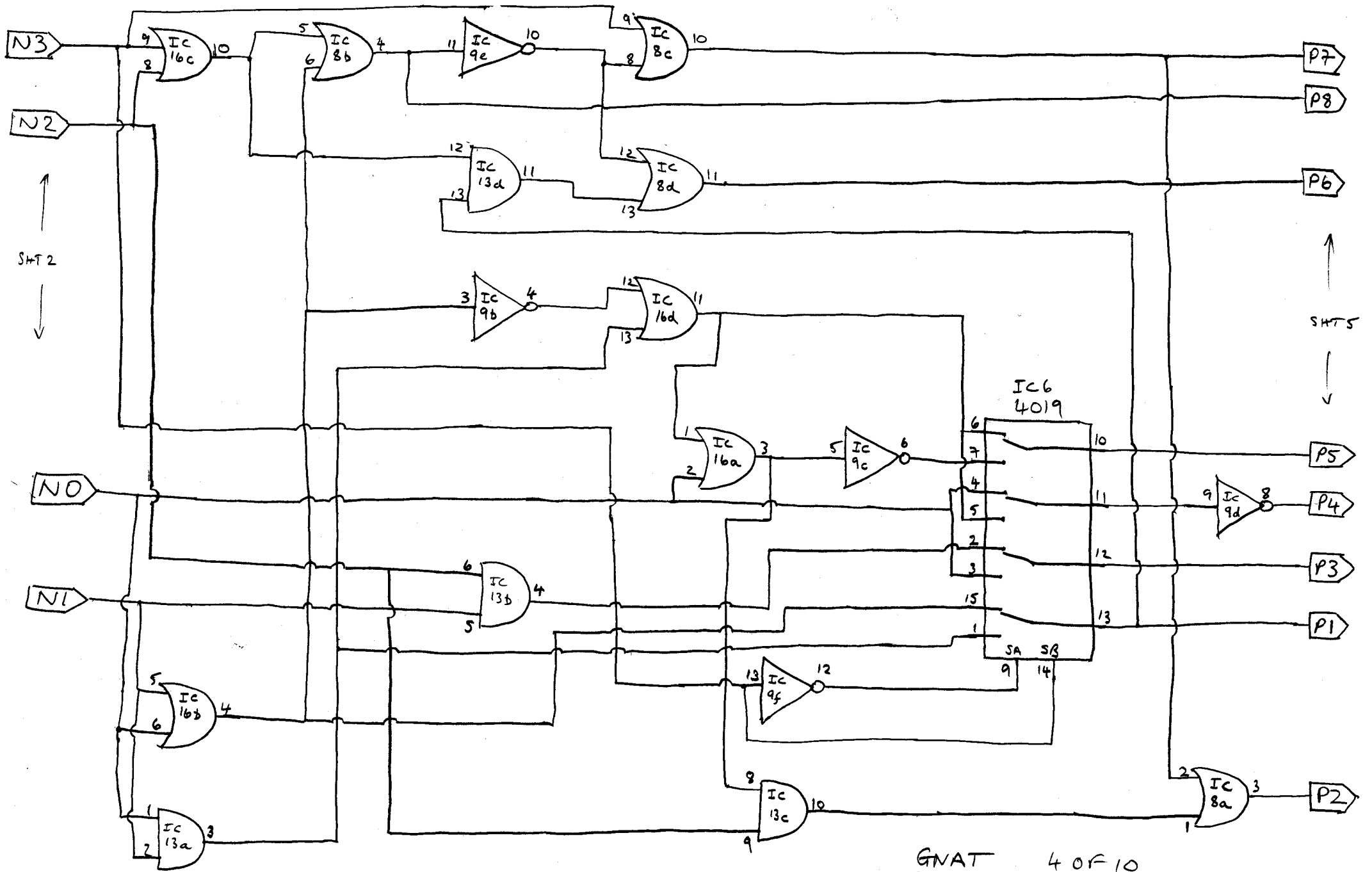

GNAT 4 OF 10
NOTE DIVISION ENCODING

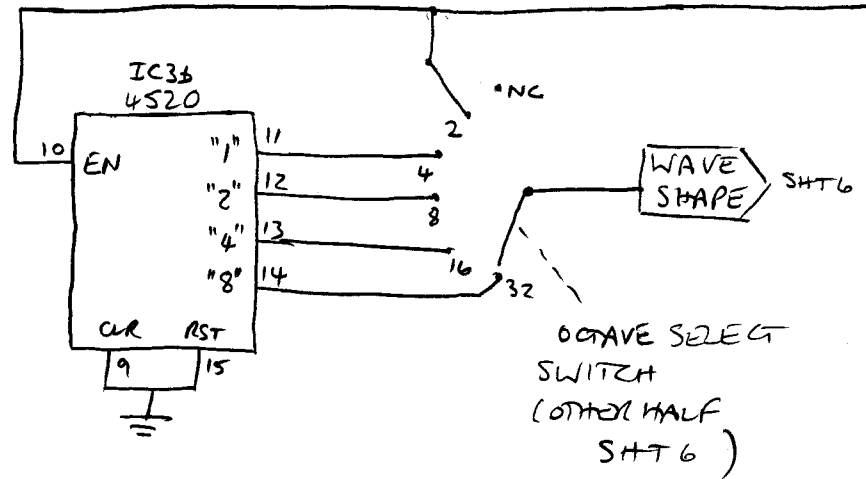
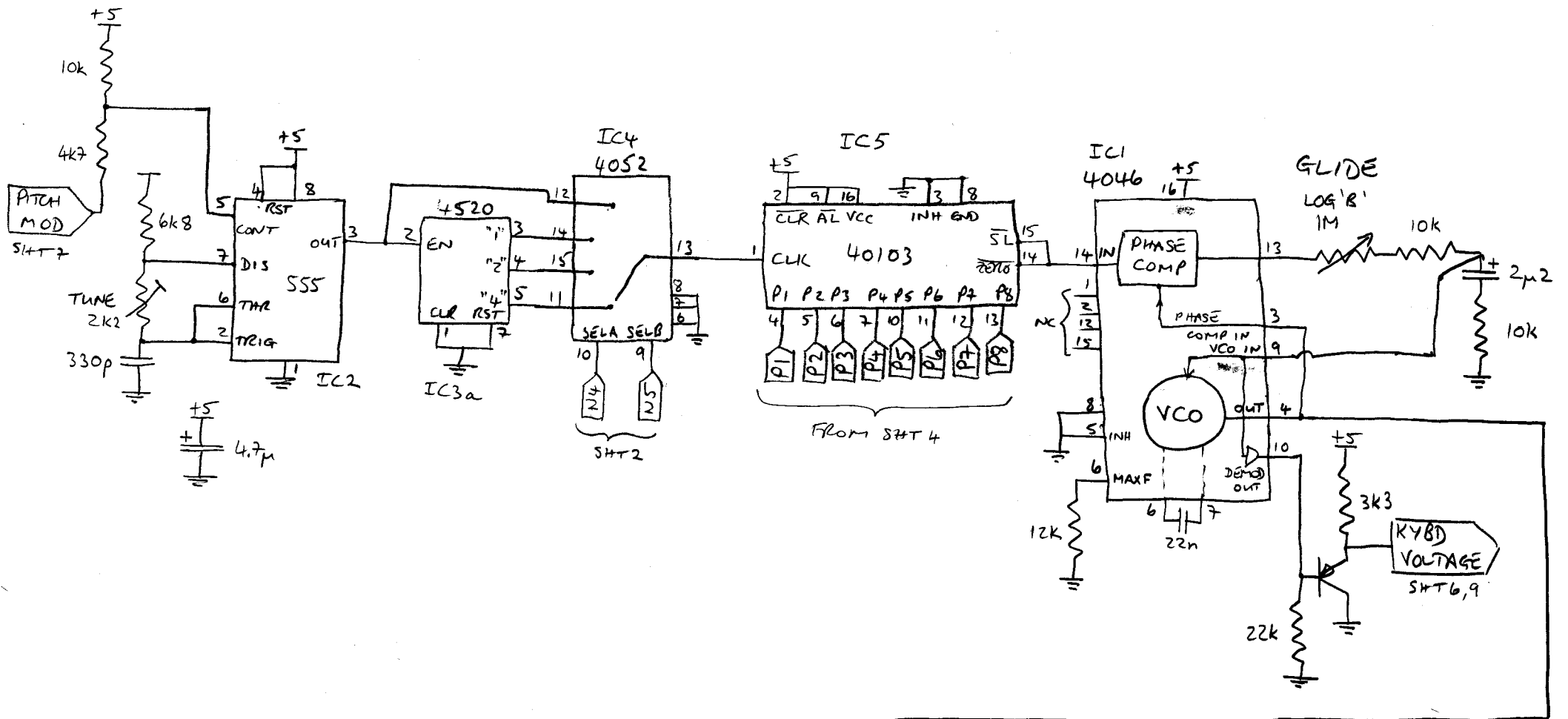

GNAT 5 OF 10
 OSCILLATOR,
 GLIDE,
 FREQUENCY DIVISION

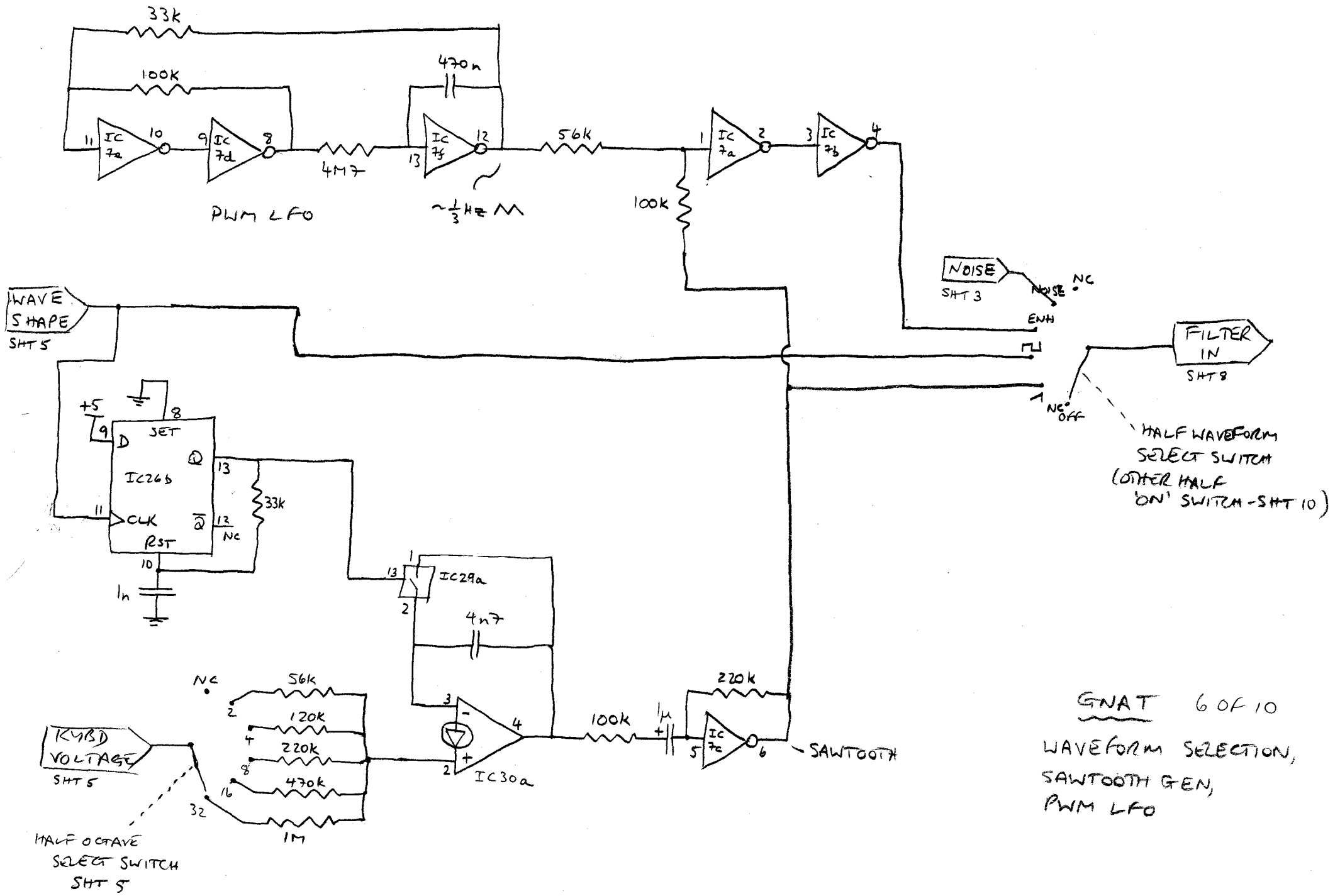

GNAT 6 OF 10
 WAVEFORM SELECTION,
 SAWTOOTH GEN,
 PWM LFO

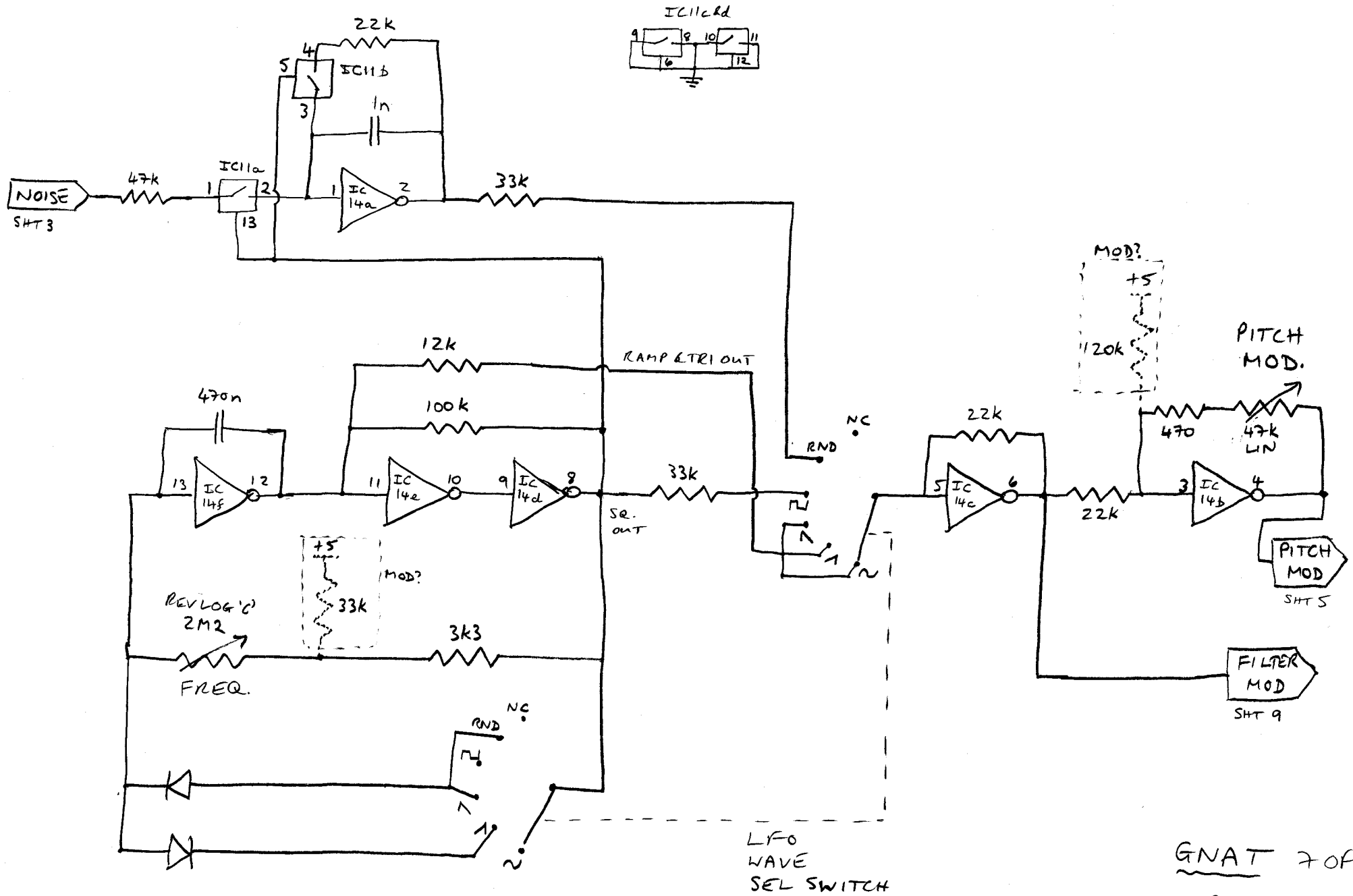

GNAT 70F10
LFO

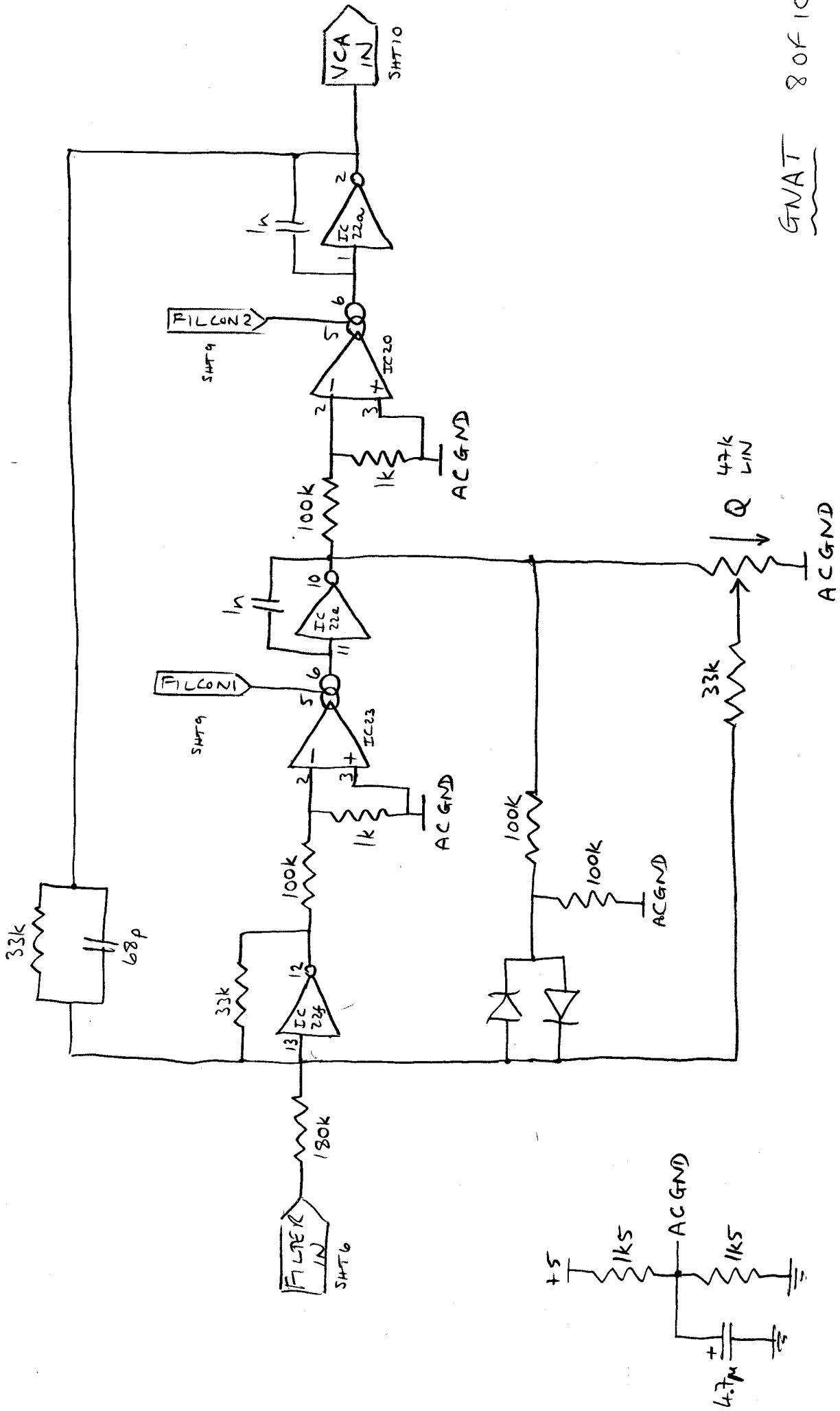

GNAT 8 OF 10

LOW-PASS FILTER

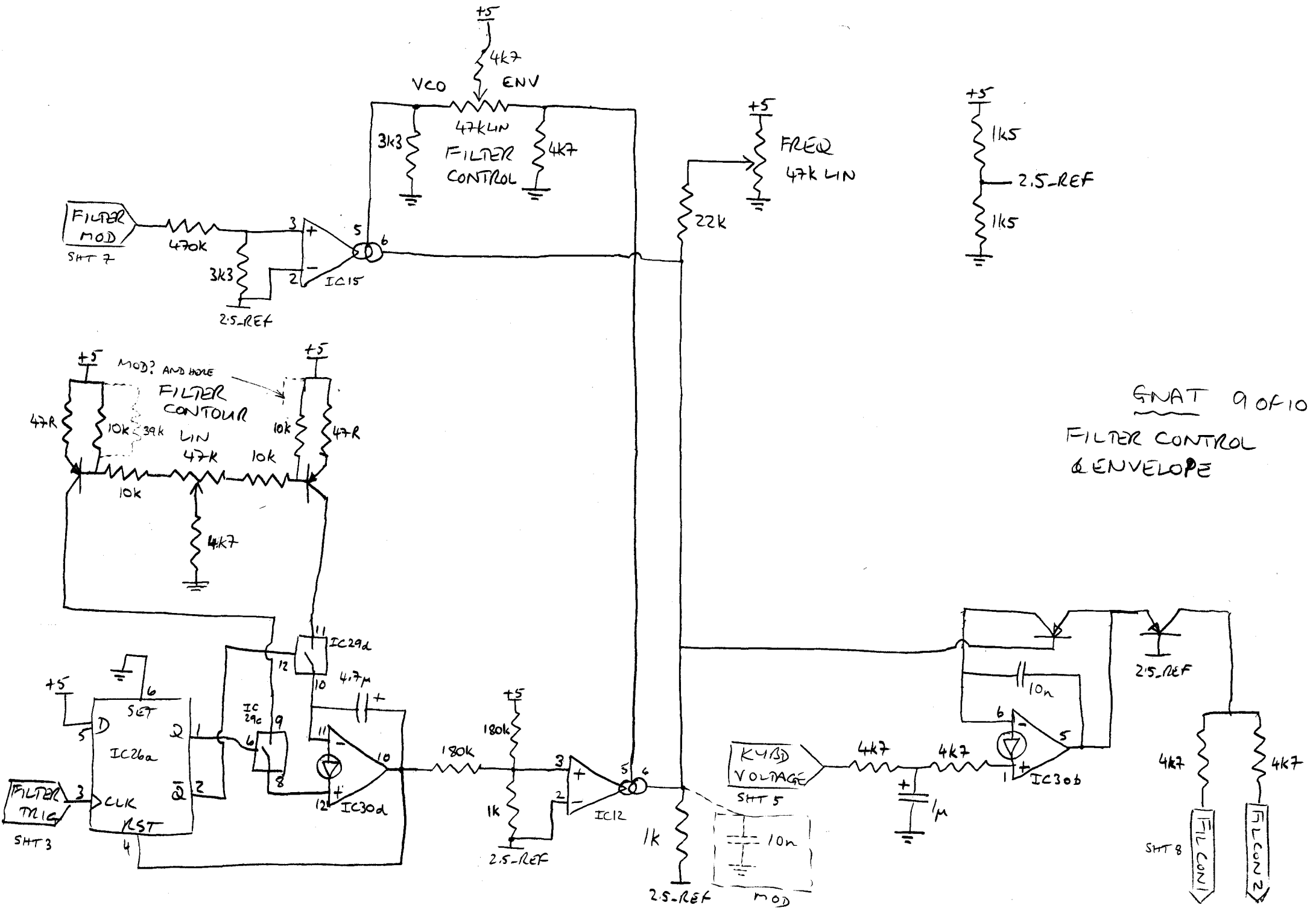

SNAT 90F10
 FILTER CONTROL
 & ENVELOPE

DECAY

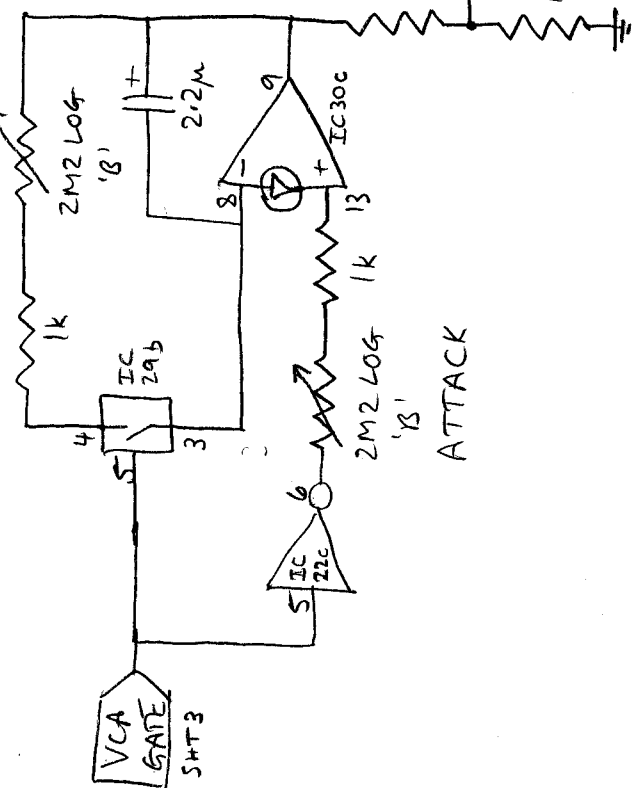

ATTACK

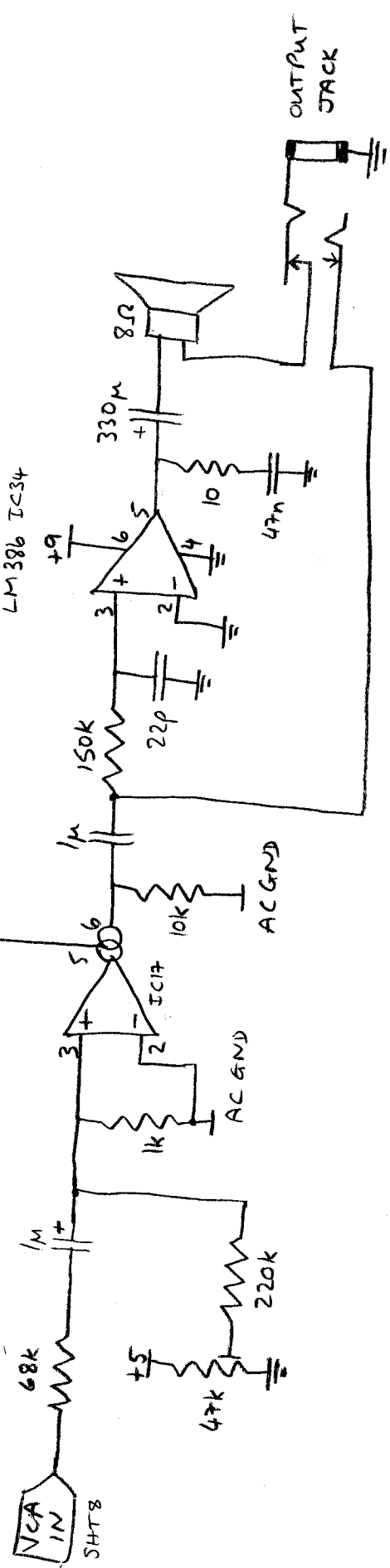
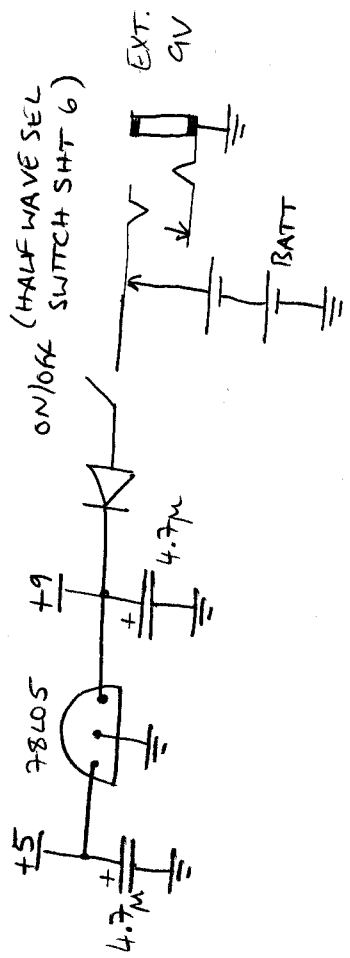

GNAT 10 OF 10
 VCA
 VCA ENV GEN
 O/P AMP, POWER

Note Digital Encoding

EDP desig	F	E	D	C	B	A	Gnat				Wasp				
	Digital encoding						4051				4028				
	4040 output pins:						Inh	Sel C	Sel B	Sel A	D	C	B	A	active
Note	14	12	13	4	2	3	13.4	12	13+14	14+4	14	12	13	4	o/p
C (top)	0	0	0	0	0	0		0	0	0	0	0	0	0	q0
B	0	0	0	0	0	1		0	0	0	0	0	0	0	q0
A#	0	0	0	0	1	0		0	0	0	0	0	0	0	q0
A	0	0	0	0	1	1		0	0	0	0	0	0	0	q0
G#	0	0	0	1	0	0		0	0	1	0	0	0	1	q1
G	0	0	0	1	0	1		0	0	1	0	0	0	1	q1
F#	0	0	0	1	1	0		0	0	1	0	0	0	1	q1
F	0	0	0	1	1	1		0	0	1	0	0	0	1	q1
E	0	0	1	0	0	0		0	1	0	0	0	1	0	q2
D#	0	0	1	0	0	1		0	1	0	0	0	1	0	q2
D	0	0	1	0	1	0		0	1	0	0	0	1	0	q2
C#	0	0	1	0	1	1		0	1	0	0	0	1	0	q2
not used	0	0	1	1	0	0	1				0	0	1	1	nc
	0	0	1	1	0	1	1				0	0	1	1	
	0	0	1	1	1	0	1				0	0	1	1	
	0	0	1	1	1	1	1				0	0	1	1	
C	0	1	0	0	0	0		1	0	0	0	1	0	0	q4
B	0	1	0	0	0	1		1	0	0	0	1	0	0	q4
A#	0	1	0	0	1	0		1	0	0	0	1	0	0	q4
A	0	1	0	0	1	1		1	0	0	0	1	0	0	q4
G#	0	1	0	1	0	0		1	0	1	0	1	0	1	q5
G	0	1	0	1	0	1		1	0	1	0	1	0	1	q5
F#	0	1	0	1	1	0		1	0	1	0	1	0	1	q5
F	0	1	0	1	1	1		1	0	1	0	1	0	1	q5
E	0	1	1	0	0	0		1	1	1	0	1	1	0	q6
D#	0	1	1	0	0	1		1	1	1	0	1	1	0	q6
D	0	1	1	0	1	0		1	1	1	0	1	1	0	q6
C#	0	1	1	0	1	1		1	1	1	0	1	1	0	q6
not used	0	1	1	1	0	0	1				0	1	1	1	nc
	0	1	1	1	0	1	1				0	1	1	1	
	0	1	1	1	1	0	1				0	1	1	1	
	0	1	1	1	1	1	1				0	1	1	1	
C (btm)	1	0	0	0	0	0		0	1	1	1	0	0	0	q8
4040 reset	1	0	0	0	0	1		14 AND 3			q8 AND 3				q8

Notes:

1. The Gnat and Wasp both have 25 notes, so span 3 octaves: if the top two bits represent which octave, 4 bits are needed to cover the 12 notes within each octave. This leaves 16-12=4 numbers per octave that are not used. The way the Wasp and Gnat handle these gaps is quite different. The Gnat switches the keys through a 4051/multiple 4052 combination, and inhibits the 4051 during the unwanted counts. The Wasp uses a 4028/4016/multiple 4052 combination, and there are no connections at the 4028 at the unwanted counts.
2. In the 4051 column, the 'Inh', 'Sel C' etc. refer to the 4051 input lines; underneath are the 4040 pins driving these, in the appropriate combinations, e.g. '13.4' is 'pin 13 AND pin 4', '13+14' is '13 OR 14' etc.
3. In the 4028 column, the letters refer to the 4028 inputs; underneath are the 4040 pins driving them (just the columns at left repeated so the patterns can be seen). The 'qx' refer to the output line of the 4028 driven high according to the given inputs; 'nc' means that line is 'not connected' (to any 4016 switch).
4. In both the Wasp and Gnat the same 4052 select lines are driven by the same 4040 pins: 'Sel A' by pin 3; 'Sel B' by 2.
5. 'EDP desig' refers to the original designation of the equivalent of these lines at the tri-statable interface (i.e. between the buffers), as shown on the Wasp hand-drawn schematics.
6. Where obvious, some entries have been omitted for clarity.